

The Oaktron 93038 midwoofer is a great addition to pro-audio systems looking to cover a wide frequency band. A high-energy ferrite magnet, a treated and engineered paper cone, and a treated cloth surround with an added edge damper make this driver a must-have for top quality sound.

- Midwoofer
- 6.5" (165 mm) basket diameter
- 50 watts, 8 ohms, 91 dB SPL
- 1.5" copper voice coil, nomex former
- Ferrite magnet, stamped-steel basket
- Engineered paper cone, treated cloth surround

MISCO engineers test and analyze the performance of these speakers using the world's most sophisticated loudspeaker measurement systems including the Klippel Analyzer and the Klippel QC, which are used to validate final design.

Oaktron by MISCO is the premium line of high performance, ready-to-ship transducers for a wide variety of applications including high fidelity, musical instrument, automotive and many more. From elegantly simple to highly specialized designs for unique and demanding applications, there is an Oaktron loudspeaker perfectly suited for your needs.

Pair this woofer with one of our [MISCO Amplifiers](#).



### Primary Specifications

<b>Size, Nominal (inch &amp; mm)</b>	6" (152 mm)
<b>Rated Impedance (<math>\Omega</math>)</b>	8
<b>Continuous Power (W)</b>	50
<b>Sensitivity (dB SPL) <sup>1</sup></b>	91
<b>Frequency Range (Hz)</b>	100 - 5,000
<b>Resonant Frequency (Fs) (Hz) +/- 15%</b>	42

### More Specifications

<b>Application</b>	Home Audio, Pro Sound
<b>RoHS Compliant</b>	No
<b>DC Resistance (Re) (<math>\Omega</math>)</b>	6.7
<b>Program Power (W)</b>	100
<b>Continuous Power (W)</b>	50

### Small Signal Parameters

<b>Nominal Impedance (Z) (<math>\Omega</math>)</b>	8
<b>DC Resistance (Re) (<math>\Omega</math>)</b>	6.7
<b>Voice Coil Inductance (Le) (mH)</b>	0.72
<b>Resonant Frequency (Fs) (Hz) +/- 15%</b>	42
<b>Mechanical Q Factor (Qms)</b>	7.86
<b>Electrical Q Factor (Qes)</b>	0.43
<b>Total Q Factor (Qts)</b>	0.41
<b>Moving Mass (Mms) (gm)</b>	10.7
<b>Suspension Compliance (Cms) (mm/N)</b>	1.38
<b>Mechanical Resistance (Rms) (kg/s)</b>	0.35
<b>Surface Area of Diaphragm (Sd) (cm<sup>2</sup>)</b>	151.8
<b>Compliance Equivalent Volume (Vas) (L)</b>	44.82
<b>Maximum Linear Excursion (Xmax) (mm)</b>	3.5
<b>Coil Winding Height (mm)</b>	13.3
<b>Magnetic Gap Height (mm)</b>	6.4
<b>Motor Force Factor (BL) (T•M)</b>	6.6
<b>Efficiency (<math>\eta_0</math>) (%)</b>	0.71
<b>Efficiency Bandwidth Product (EBP) (Fs/Qes)</b>	96.1

### Material Descriptions

<b>Basket Type</b>	Stamped steel with black powder coat
<b>Terminal Size (mm)</b>	5.2 X 0.5 mm
<b>Voice Coil Diameter (mm)</b>	38.7
<b>Voice Coil Wire Material</b>	Copper
<b>Voice Coil Former Material</b>	Nomex
<b>Magnet Material</b>	Ferrite
<b>Magnet Weight (g)</b>	568
<b>Cone Body Material</b>	Engineered paper cone, treated

<b>Cone Surround Material</b>	Treated cloth with added edge damper
<b>Spider Material</b>	Flat formed cloth
<b>Dust Cap Material</b>	Treated paper dome
<b>Net Weight (kg)</b>	1.93



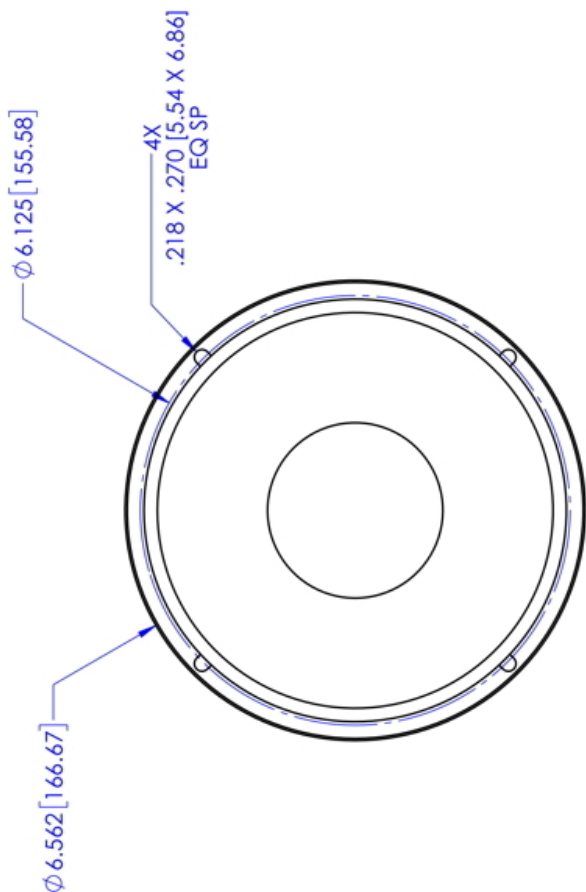
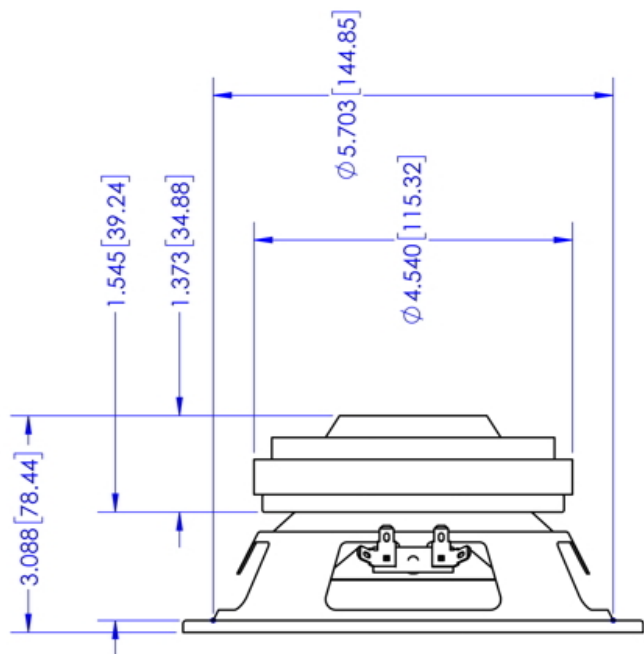

MODEL: 165-WF08-02 P/N: 93038

OAKTRON  
by **MISCO**